

Specifications

Input Voltage	120/277 VAC
Power Consumption	0.5 mA
Radio Frequency	2.4 GHz
RF Transmission Output Power (Average)	+5 dBm
Operating Environment	40 to 120 deg F, dry location
Dimensions	See drawing
Wires	9' 600 VAC plenum rated, 18 AWG solid conductors
Sensor Input Channels (2)	0 - 30 VDC
Configuration Programming	Configuration programming stored in non-volatile memory
Mounting	Mounts in double gang box. Requires a wallplate with a decorate opening and a blank

Ordering Information

Catalog Number	Description
WCI	Wall Control Interface
WCI Kit-I	Kit with WCI and ivory decorator switch
WCI Kit-W	Kit with WCI and white decorator switch

Class A Digital Devices

This equipment has been tested and found to comply with the limits for a Class A digital device, pursuant to Part 15 of the FCC Rules. These limits are designed to provide reasonable protection against harmful interference when the equipment is operated in a commercial environment. The equipment generates, uses and can radiate radio frequency energy and, if not installed and used in accordance with the instruction manual, may cause harmful interference to radio communications. Operation of the equipment in a residential area is likely to cause harmful interference in which case the user will be required to correct the interference at his/her own expense.

To comply with RF exposure compliance requirements, for mobile configurations, a separation distance of at least 20 cm must be maintained between the antenna of this device and all persons. This device must not be co-located or operating in conjunction with any other antenna or transmitter.

WARRANTY INFORMATION

Adura warrants to Buyer that the platform control devices, associated sensors, network components (including Adura Gateway and Gateway hardware) purchased from Adura (collectively, "Hardware") will conform to their written specifications and be free from defects in workmanship and material under normal use and service for 1 year from date of delivery to Buyer or the date of manufacture based on the serial number if the date of delivery cannot be reasonably ascertained ("Hardware Warranty Period"). Adura passes through manufacturers' warranties, if any, as permitted for third party hardware which may be supplied with the system and Buyer agrees to look only to such third party vendors for any warranty claims relating thereto. For Hardware not conforming to this limited Hardware warranty during the Hardware Warranty Period, as its sole responsibility, Adura, at its option, will repair or replace the defective Hardware with new or equivalent to new components and Hardware so long as Buyer provides written notice of a covered, reproducible defect during the Hardware Warranty Period, Buyer complies with Adura's return material authorization process ("RMA Process") and is otherwise in compliance with this warranty. Repaired Hardware will be covered by this limited Hardware warranty for the longer of the remaining term of the Warranty Period or 30 days from shipment of the repaired Hardware to the Buyer. Adura owns all parts removed from the Hardware for which a replacement was provided. Visit www.aduratech.com for list of exclusions and disclaimers.



101 Second Street, Suite 575 • San Francisco, CA 94105
Tel: 1.888.828.8281 • www.aduratech.com

WCI 12.09

INSTALLATION INSTRUCTION MANUAL

wall control interface

The Wall Control Interface is to be used to control lighting in commercial and industrial buildings. It is to be installed with a low voltage wall switch in place of a conventional line voltage wall switch. When an occupant presses the wall switch, the Wall Control Interface transmits the occupant's request for more or less lighting via radio frequency.

The Wall Control Interface is intended to be used in a network of devices which communicate wirelessly, such as Light Controllers, wall control devices and software management tools.

The Wall Control Interface mounts inside an electrically rated junction box behind a UL listed wallplate. Often, the Wall Control Interface will be mounted in an existing junction box that was previously used for one or more wall switches. The Wall Control Interface is designed to screw into standard gang box mounting holes. **There is a 30 second warm-up period when power is first applied to the device.**

If your installation requires mounting in an alternate size junction box, please contact Adura's® technical support. The Wall Control Interface is designed to work with a low voltage momentary switch (such as a Leviton model 56081-2).

Installation Materials (Not Supplied)

Wiring connectors. All existing wiring connectors must be replaced with new UL listed wiring connectors, either wire nuts or captive-type connectors. All wiring connectors must be correctly sized for the application, the number and the size of the electrical conductors.

CAUTION

- Disconnect all power before installation or service.
- All installation and maintenance work must be performed by qualified personnel.
- The Wall Control Interface must be installed in accordance with state, local and national electrical codes and requirements.



You will need to confirm that a double gang box has adequate available space.

IF YOU ENCOUNTER A SITUATION OTHER THAN DESCRIBED BELOW, PLEASE CONTACT ADURA TECHNOLOGIES FOR TECHNICAL SUPPORT.

Installation Instructions

Read these instructions in their entirety before performing any installation work.

1. Turn off all power to circuit by switching the circuit breaker off.
2. Remove the existing wallplate from the wall switch location.
3. Unscrew the wall switches and pull forward. Before loosening the wires, verify that power is off to the wall switch. If power is present, stop work and identify and switch off the circuit breaker.
4. Remove both switches for bi-level switching applications.
5. Using a wire nut sized for the application, connect the hot conductor, all switched legs and the black wire on the Wall Control Interface. Verify that all wires are secured by the wire nut.
6. Connect the green wire on the Wall Control Interface to the ground wire in the junction box. If no ground wire is present, then attach the green wire to the junction box with a ground screw.
7. Connect the 3 low voltage conductors to a UL listed low voltage wall switch (for example, Leviton model 56081-2).

- The low voltage gray conductor on the Wall Control Interface connects to the common of the wall switch.
- The low voltage blue conductor attaches to the ON terminal of the wall switch.
- The low voltage yellow conductor attaches to the OFF terminal on the wall switch.

8. Install the wall switch on the desired side of the double gang opening. Secure the wall switch with screws to the holes provided for device mounting. Secure the Wall Control Interface in the other opening with screws to the holes provided for device mounting.

8. Attach a new wallplate with one side blank (for example, Leviton model 80708 or 80607-W for a two gang switch box).

THERE IS A 30 SECOND WARM-UP PERIOD WHEN POWER IS FIRST APPLIED TO THE WALL CONTROL INTERFACE.

Dimensions

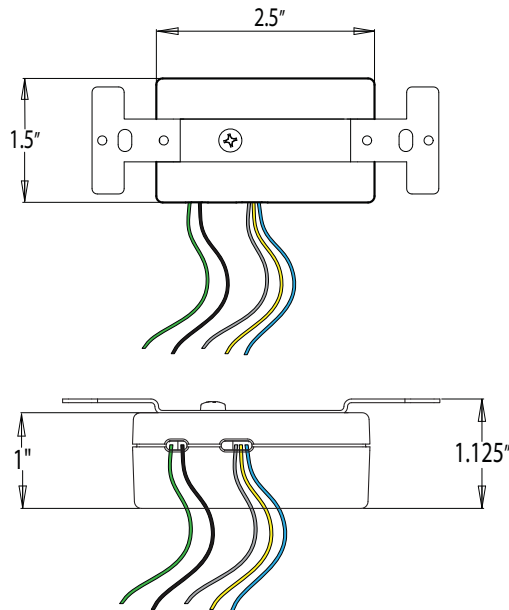

Wiring Diagram

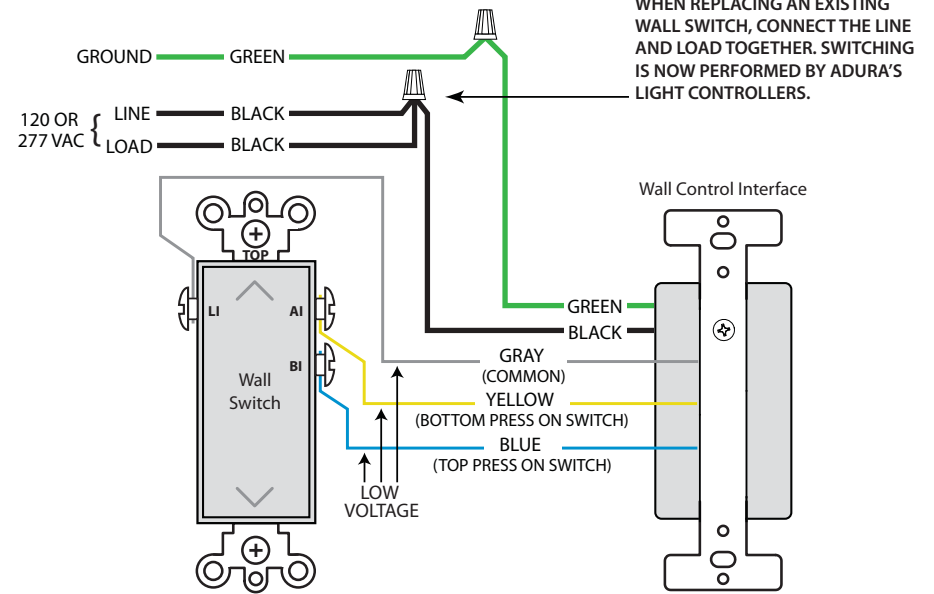

WCI mounts in a double gang switch box alongside a low voltage switch.

WCI available individually or in a kit with a decorator style center off momentary toggle switch.

Desired wallplate size/design must be purchased separately.

Decorator Opening

